

BWE-80, 110 & 130 Upright Mixer



Compact And Robust Professional Mixer

- The builders choice for portability and safety
- Loads or tips either side for fast operations
 - Barrow height discharge
 - Easy to maintain
- CE compliant, with NVR (No Volt Return)
Safety power switch
- Extra light weight vertical mixers, easily manoeuvrable, compact design

www.BelleGroup.com

No.1 for Light Construction Equipment

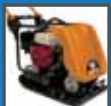

COMPACTING...

MIXING...

CONCRETING...

CUTTING...

BREAKING...

MOVING

Compact and robust **professional** mixer. Ideal compromise between medium and **high** capacity professional **performance** machines. These upright mixers use a proven motor gear system to provide reliable mixing.

Technical Specifications

| | | |
|-------------------|---------|---------------|
| Model | | BWE 80 |
| Part Number | | MU01 |
| Voltage | (V) | 230 |
| Motor Power | (Hp/kW) | 0.9/0.7 |
| Current | (Amp) | 3.8 |
| Power Consumption | (w) | 700 |
| Frequency | (Hz) | 50 |
| Protective System | | IP44 |
| Drum Volume | (ltr) | 130 |
| Mixing Output | (ltr) | 80 |
| Drum Speed | (rpm) | 29 |
| Weight | (kg) | 73 |
| Noise Level | (dB(A)) | 90 |



| | | |
|-------------------|---------|----------------|
| Model | | BWE 110 |
| Part Number | | MU02 |
| Voltage | (V) | 230 |
| Motor Power | (Hp/kW) | 1.2/0.9 |
| Current | (Amp) | 3.8 |
| Power Consumption | (w) | 900 |
| Frequency | (Hz) | 50 |
| Protective System | | IP44 |
| Drum Volume | (ltr) | 165 |
| Mixing Output | (ltr) | 110 |
| Drum Speed | (rpm) | 29 |
| Weight | (kg) | 75 |
| Noise Level | (dB(A)) | 90 |

| | | |
|-------------------|---------|----------------|
| Model | | BWE 130 |
| Part Number | | MU29 |
| Voltage | (V) | 230 |
| Motor Power | (Hp/kW) | 1.2/0.9 |
| Current | (Amp) | 3.8 |
| Power Consumption | (w) | 900 |
| Frequency | (Hz) | 50 |
| Protective System | | IP44 |
| Drum Volume | (ltr) | 180 |
| Mixing Output | (ltr) | 130 |
| Drum Speed | (rpm) | 29 |
| Weight | (kg) | 77 |
| Noise Level | (dB(A)) | 90 |

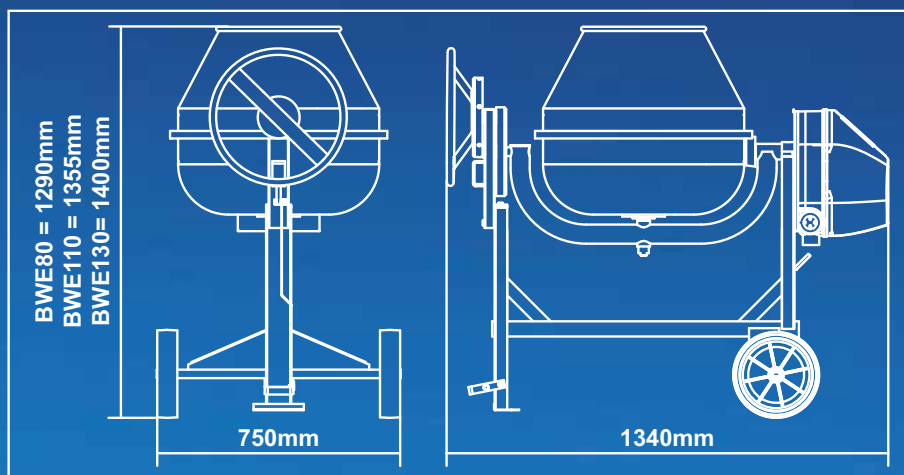

Belle Group Head Office
Sheen, Nr. Buxton
Derbyshire, SK17 0EU
Tel: (+44) 01298 84606
Fax: (+44) 01298 84722
Email: sales@belle-group.co.uk

Dealer Stamp:

www.BelleGroup.com

Belle Group reserve the right to amend or improve any specifications in this brochure without notice.